

SERIES 300

2D Bulkhead

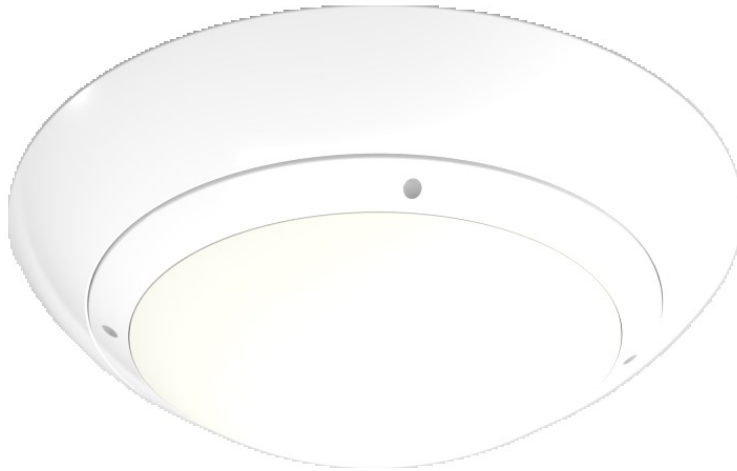

OVERVIEW

The Series 300 is an IP65 anti-ligature LED bulkhead for use in secure healthcare applications. The luminaire is provided with an IK10 Opal diffuser and is available in 2 different outputs of 1800 and 2800 lumens and choice of 3000 or 4000K. Series 300 can also be controlled via dali, Bluetooth or retractive dimming, and has a choice of emergency options for excellent flexibility in a wide range of applications.

FEATURES

- Anti-Ligature design to prevent self harming
- IP65 and IK10 rating for the harshest of environments.
- 2 output options, make it suitable for a myriad of applications
- 125 to 128 delivered Lumens per Watt
- Premium European drivers from VS, Osram and Tridonic
- Emergency options
- >50,000 hours lifetime with 5 year warranty

OPTIONS

- 3000 or 4000K
- 1800 or 2800 lumens options
- Dimming control via Dali or wireless via Bluetooth
- Emergency self-test or manual versions

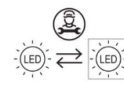

T: 01282 476600 | E: info@photonicleighting.co.uk

Unit 1 Boran Court, Network 65, Hapton, Burnley BB11 5TH

www.photonicleighting.co.uk

SERIES 300

2D Bulkhead

PRODUCT DIMENSIONS

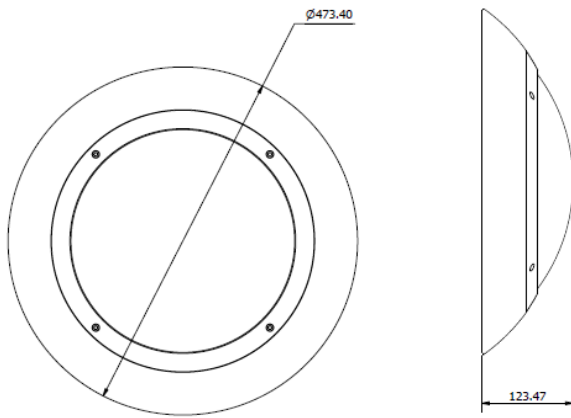

PHOTOMETRIC

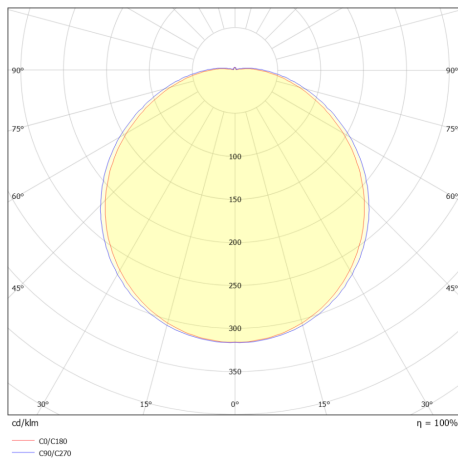

T: 01282 476600 | E: info@photonighting.co.uk

Unit 1 Boran Court, Network 65, Hapton, Burnley BB11 5TH

www.photonighting.co.uk

SERIES 300

2D Bulkhead

PRODUCT SPECIFICATION

300 - W - 65 - (LM) - (CCT) - (OP) - (CTR)

Lumen Output (LM)	
Code	Description
18	1800lm
28	2800lm

Correlated Colour Temperature (CCT)	
Code	Description
830	3000K 80 CRI
840	4000K 80 CRI

Beam angle (OP)	
Code	Description
O	Opal Diffuser

Control (CTR)	
Code	Description
N	Non dim
D	DALI
RD	Retractive Dim
MO	Microwave On/Off
BC	Bluetooth Casambi

Emergency (EM)	
Code	Description
L3	3W Lithium
SL3	3W Self test lithium

T: 01282 476600 | E: info@photoniclighting.co.uk

Unit 1 Boran Court, Network 65, Hapton, Burnley BB11 5TH

www.photoniclighting.co.uk