

SERIES 335

2D STYLE BULKHEAD

PHOTONIC.
LIGHTING SOLUTIONS



OVERVIEW

An IP65 2-D style luminaire, Series 335 is an easy to install bulkhead with CCT colour options 3000K, 4500K, 6000K. Series 335 offers excellent light distribution with both emergency and microwave sensor options and can be mounted on wall or ceiling for residential and commercial application.

FEATURES

- Colour switchable from 3000, 4500 & 6000K
- IP65 for exterior or interior application
- High LED Chip Density for even illumination
- Emergency version available
- 35,000 hours' lifetime with 5-year warranty

OPTIONS

- Colour options 3000k, 4500k, 6000K
- Microwave On/Off Sensors
- Emergency Option



PRODUCT DIMENSIONS

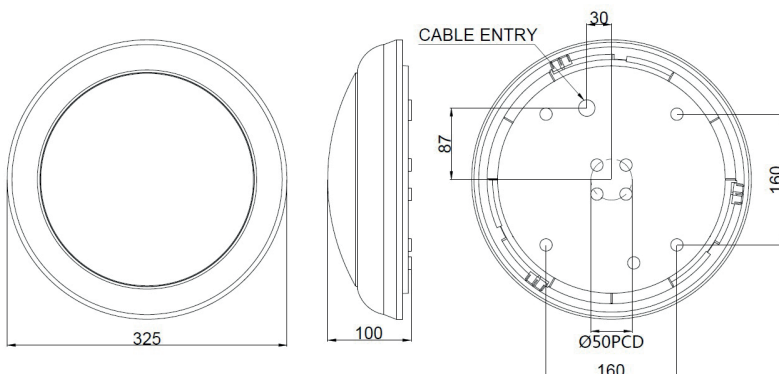

01282 476600 | info@photonicleighting.co.uk

Unit 1 Boran Court, Network 65, Hapton, Burnley BB11 5TH

www.photonicleighting.co.uk



Side view



CCECO luminaire corridor installation

PHOTOMETRIC PERFORMANCE

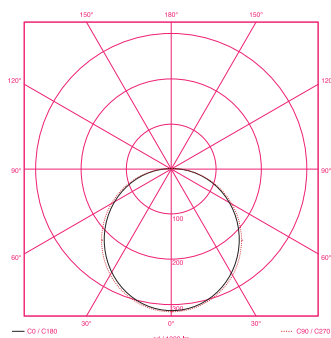

PRODUCT SPECIFICATION

335 - W - 18 - 65 - OP - CCT - CTRL - EMG

Colour (CLR)	
Code	Description
W	White

Lumens (LM)	
Code	Description
18	1800

IP Rating (IP)	
Code	Description
65	IP65

Beam Angle (BA)	
Code	Description
OP	Opal

CCT (CCT)	
Code	Description
830	80 CRI 3000K
845	80 CRI 4500K
860	80 CRI 6000K

Control (CTRL)	
Code	Description
N	No Controls
D	Dali
MD6	Microwave Dimming
MO	Microwave on/off

Emergency (EMG)	
Code	Description
L3	3W Lithium
SL3	3hr 3W Lithium Self-test
L2	2W Lithium

ABOUT PHOTONIC

Photonic provide project-based lighting solutions for electrical contractors, specifiers and end clients, based around the latest technologies for industry & warehousing, office & commercial, education, and healthcare. We are flexible and agile, quick and effective, delivering project solutions to our clients.

Based in the UK, we take ownership of the lighting on a project, providing full support in terms of site surveys, lighting calcs, payback calculations and project samples, to ensure value-driven solutions on every project.

CALL OUR PROJECT SUPPORT TEAM FOR YOUR SPECIFIC REQUIREMENTS ON 01282 476600

